

# HL-T1

SERIES

## Ultra-compact Laser Collimated Beam Sensor

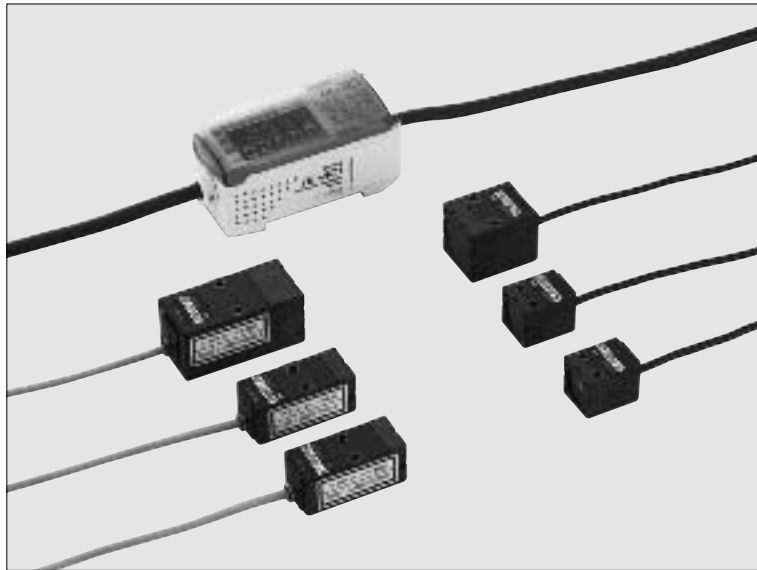

The industry's smallest sensor head  
A high-functionality intelligent controller



Conforming to EMC Directive

### The industry's smallest sensor head

The most compact size and yet the highest level of performance in their class. These sensors save space.

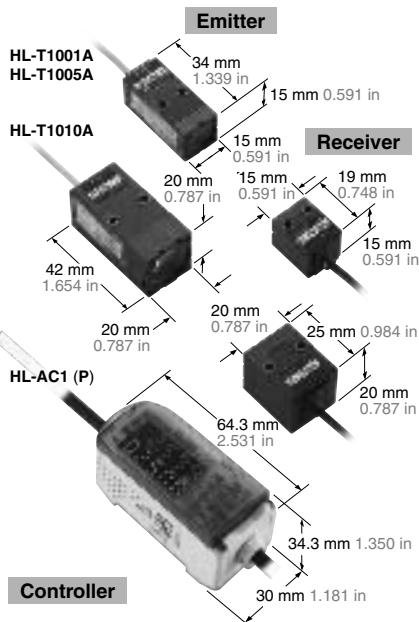

### FDA standards conforming types are available

FDA standards conforming types, most suitable for equipment used in the USA, are now available.

FDA : Class II  
IEC / JIS : Class 1

### Long sensing range

Long sensing range of 500 mm 19.685 in (HL-T1005A, HL-T1010A) and 2 m 6.562 ft (HL-T1001A) are available.

### Adoption of a Class 1 laser

The adoption of a Class 1 laser (IEC / JIS) eliminates the need for safety countermeasures, so that these sensors can be used in photo-electric sensor applications with confidence.

### High-precision judgment even from minute differences in light intensity

The sensors are sensitive to minute differences in light intensity, so that they can judge even the opacity of glass and turbidity of liquids. In addition, the amount of light received can be displayed as a percentage to allow you to determine permeation rates.



### Resolution of 4 μm 0.157 mil

A high resolution of 4 μm 0.157 mil (at an average 64 cycles) allows high-precision positioning and size judgment.

### Distinguishing size of electronic components

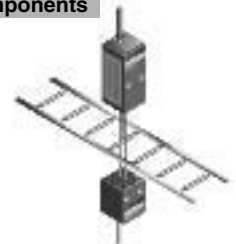

### Minimum sensing object diameter φ 8 μm φ 0.315 mil HL-T1001A

The laser with a beam diameter of φ 1 mm φ 0.039 in can sense extremely small objects with dimensions in micrometers such as bonding wires.

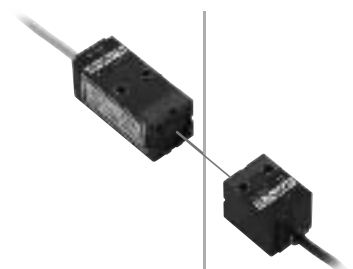

## 3 types of teaching functions are now available

3 types of teaching functions are available: positioning teaching / 2-level teaching / automatic teaching, thus enabling a variety of applications to be accommodated for many different types of production sites.

Positioning teaching	The actual value measured at the time when teaching is performed is utilized as the threshold value. Best suited for high-precision positioning.
2-level teaching	In this teaching method, an intermediate level between the first and the second teaching levels is utilized as the threshold value. Minute differences, such as changes as small as the thickness of a sheet of paper between the sensing objects, can be detected when this teaching method is utilized.
Automatic teaching	With this teaching method, a series of periodic arbitrarily measurements are taken automatically and an intermediate value, between the maximum and minimum values obtained by this measurement, is utilized as the threshold value. The threshold value is therefore set in relation to the sensing object. Best suited for applications in which teaching must be performed without stopping the current flow of operations.

## Calculations for 2 sensors are possible

The calculation unit (optional) just needs to be connected between the two controllers to enable calculations (addition and subtraction) to be carried out for two sensors. No digital panel controller is needed either.

### Sheet width measurement

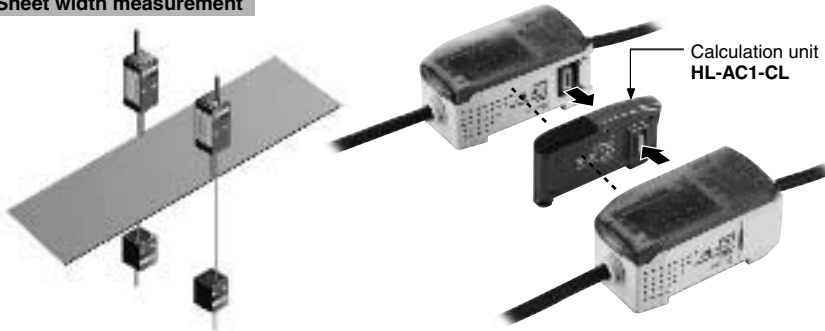

## Analog output is switchable between current / voltage

The analog output can be switched between either of two different outputs; current (4 to 20 mA) / voltage ( $\pm 4$  V). With the monitor focus function, the output can be adjusted over the range from  $-5$  V to  $+5$  V, or from 0 V to  $+5$  V, facilitating connectivity with a variety of output devices.

### Monitor focus function

The linear output is fully adjustable over the following range (current: 4 to 20 mA / voltage  $\pm 4$  V). The usage of the monitor focus function together with selectable current / voltage switching for the linear output allows for compatibility with a variety of output devices.

### Examples

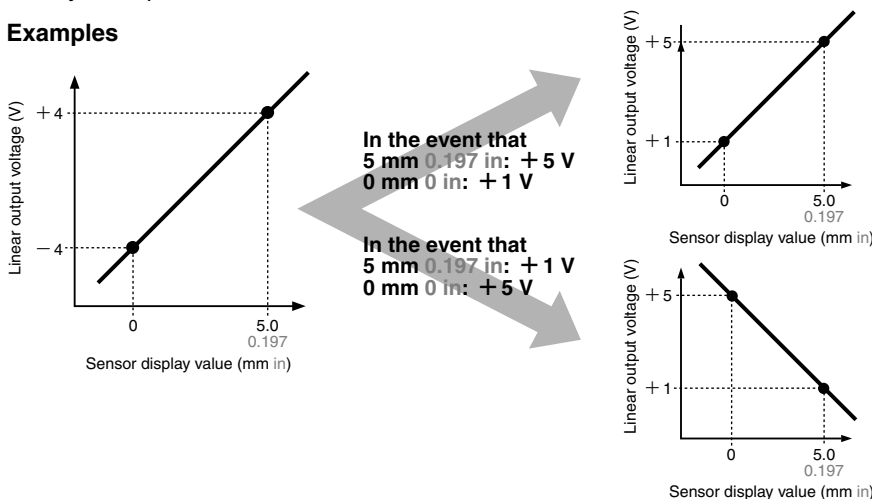

The linear output must be set by determining output values (maximum: current 0 to 23.5 mA / voltage  $\pm 5.5$  V) at two different points, for the arbitrary display value.

## Superior operability has been achieved

All settings can be easily performed by using the four-way keys and viewing the digital displays.

### Large dual digital display

After power up, the measured value (red) and the threshold value (yellow) are displayed (letter height 7 mm 0.276 in)

**Judgment output indicators**  
HIGH (Orange) / PASS (Green) / LOW (Yellow) 3-color display

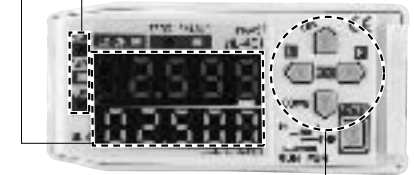

Easy operation with four-way keys

## Self-check for laser diode deterioration

The intelligent controller performs self-checking for laser diode deterioration. If the controller detects significant deterioration (end of diode life), an error will be displayed on the main digital display panel. This function enables users to prepare in advance for potential laser diode malfunctions.

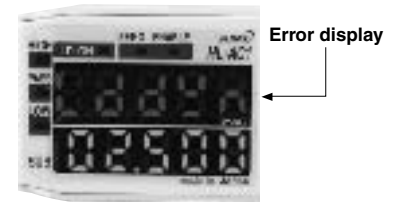

## Detection resolution can be easily confirmed

The current resolution can be easily confirmed by setting the controller to indicate resolution display mode.

By displaying the resolution, the marginal increment can be easily determined for the threshold value setting, helping to accurately determine whether sensing can be performed.

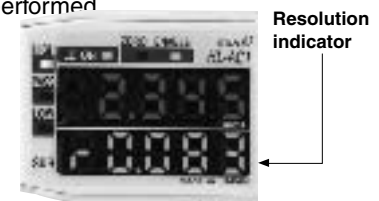

## Fully equipped with convenient functionality

A wide range of convenient features has been incorporated into the unit's compact body: standard received light setting / auto scaling setting / measurement processing (various timer and hold functions) / differentiation / monitor focus function. These features make the unit useful for a wide variety of applications.

# HL-T1

## APPLICATIONS

Checking the positioning of chip components

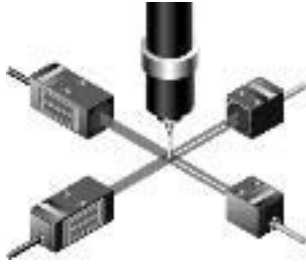

Detecting defective lead frame seating



Sensing wafer position in wafer cassette



## ORDER GUIDE

### Sensor heads

Type	Appearance	Sensing range	Sensing width	Min. sensing object	Conforming standards	Model No.
Beam diameter $\phi 1$ mm $\phi 0.039$ in type		2 m 6.562 ft	$\phi 1$ mm $\phi 0.039$ in ( $\phi 1$ to $\phi 2.5$ mm $\phi 0.039$ to $\phi 0.098$ in at 500 to 2,000 mm 19.685 to 78.740 in sensing range)	$\phi 8 \mu\text{m}$ $\phi 0.315$ mil opaque object $\phi 50 \mu\text{m}$ $\phi 1.969$ mil opaque object at 500 to 2,000 mm 19.685 to 78.740 in sensing range	IEC / JIS	<b>HL-T1001A</b>
					FDA	<b>HL-T1001F</b>
Sensing width 5 mm 0.197 in type		500 mm 19.685 in	5 mm 0.197 in	$\phi 0.05$ mm $\phi 0.002$ in opaque object	IEC / JIS	<b>HL-T1005A</b>
					FDA	<b>HL-T1005F</b>
Sensing width 10 mm 0.394 in type		500 mm 19.685 in	10 mm 0.394 in	$\phi 0.1$ mm $\phi 0.004$ in opaque object	IEC / JIS	<b>HL-T1010A</b>
					FDA	<b>HL-T1010F</b>

### Accessories

• **MS-HLT1-1**

(Sensor mounting bracket  
for **HL-T1001A(F)** /  
**HL-T1005A(F)**)

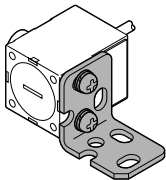

• **MS-LA3-1**

(Sensor mounting bracket for  
**HL-T1010A(F)**)

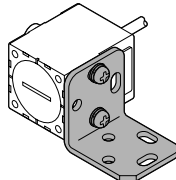

• **CN-HLT1-1**

(Sensor head to controller connection cable)

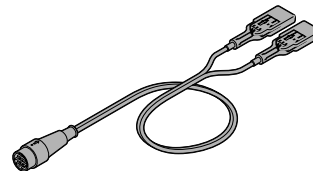

## ORDER GUIDE

### Controllers

Type	Appearance	Model No.	Output
NPN output		<b>HL-AC1</b>	<ul style="list-style-type: none"> <li>• NPN open-collector transistor (Judgment output)</li> <li>• Current / voltage output (Linear output)</li> </ul>
PNP output		<b>HL-AC1P</b>	<ul style="list-style-type: none"> <li>• PNP open-collector transistor (Judgment output)</li> <li>• Current / voltage output (Linear output)</li> </ul>

### Calculation unit

Appearance	Model No.
	<b>HL-AC1-CL</b>

## OPTIONS

Designation	Model No.	Description	
Side-view attachment	<b>HL-T1SV1</b>	For <b>HL-T1001A(F)/T1005A(F)</b> (1 pc.)	The beam axis can be bent to a right angle making universal mounting possible.
	<b>HL-T1SV2</b>	For <b>HL-T1010A(F)</b> (1 pc.)	
Controller mounting bracket	<b>MS-HLAC1-1</b>	Use when mounting the controller with screws	
Extension cable	<b>HL-T1CCJ4</b>	Length: 4 m 13.123 ft Weight: 162 g approx.	Extension cable for use between the controller and its cable linking it with the sensor head. Cabletyre cable with connectors on both ends. Cable outer diameter: $\phi$ 5.2 mm $\phi$ 0.205 in Connector outer diameter: $\phi$ 15.5 mm $\phi$ 0.610 in max.
	<b>HL-T1CCJ8</b>	Length: 8 m 26.247 ft Weight: 330 g approx.	

### Side-view attachment

- HL-T1SV1
- HL-T1SV2

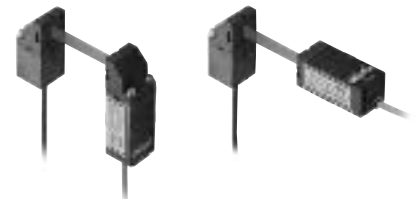

Mounted on both sides

Mounted on one side only

### Controller mounting bracket

- MS-HLAC1-1

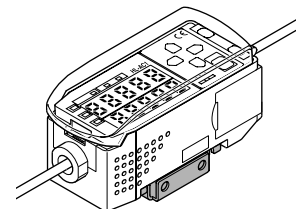

### Extension cable

- HL-T1CCJ4
- HL-T1CCJ8

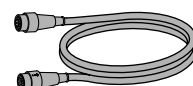

# HL-T1

## SPECIFICATIONS

### Sensor heads

Item	Model No.	Type	Beam diameter $\phi$ 1 mm $\phi$ 0.039 in type	Sensing width 5 mm 0.197 in type	Sensing width 10 mm 0.394 in type
		IEC/JIS standards conforming type	HL-T1001A	HL-T1005A	HL-T1010A
		FDA standards conforming type	HL-T1001F	HL-T1005F	HL-T1010F
Applicable controller		HL-AC1, HL-AC1P			
Sensing range		0 to 500 mm 0 to 19.685 in	500 to 2,000 mm 19.685 to 78.74 in	500 mm 19.685 in	
Sensing width		$\phi$ 1 mm $\phi$ 0.039 in	$\phi$ 1 to $\phi$ 2.5 mm $\phi$ 0.039 to $\phi$ 0.098 in	5 mm 0.197 in	10 mm 0.394 in
Min. sensing object		$\phi$ 8 $\mu$ m $\phi$ 0.315 mil opaque object	$\phi$ 50 $\mu$ m $\phi$ 1.969 mil opaque object	$\phi$ 0.05 mm $\phi$ 0.002 in opaque object	$\phi$ 0.1 mm $\phi$ 0.004 in opaque object
Repeatability (During the state in which light is half blocked)		4 $\mu$ m 0.157 mil (Note 1)	—	4 $\mu$ m 0.157 mil (Note 1)	
Linear output resolution (Note 2)		4 $\mu$ m 0.157 mil (Notes 1, 3)	—	4 $\mu$ m 0.157 mil (Note 1)	
Emission indicator		Green LED (lights up during laser emission)			
Interference prevention function		Two units of sensors can be mounted close together. (When the controller interference prevention function is used)			
Environmental resistance	Pollution degree	3 (industrial environment)			
	Ambient temperature	0 to + 50 °C + 32 to + 122 °F (No dew condensation), Storage: - 25 to + 70 °C - 13 to + 158 °F			
	Ambient humidity	35 to 85 % RH, Storage: 35 to 85 % RH			
	Ambient illuminance	Incandescent light: 10,000 lx at the light-receiving face			
	EMC	EN 50081-2, EN 61000-6-2			
	Voltage withstandability	1,000 V AC for one min. between all supply terminals connected together and enclosure			
	Insulation resistance	100 M $\Omega$ , or more, with 250 V DC megger between all supply terminals connected together and enclosure			
	Vibration resistance	10 to 500 Hz frequency, 1.5 mm 0.059 in amplitude in X, Y and Z directions for two hours each			
	Shock resistance	300 m/s <sup>2</sup> acceleration (30 G approx.) in X, Y and Z directions for three times each			
Emitting element	IEC / JIS standards conforming type	Red semiconductor laser Class 1 (IEC / JIS) (modulated, max. output: 0.2 mW, peak) (emission wavelength: 650 nm 0.026 mil)	—	Red semiconductor laser Class 1 (IEC / JIS) (modulated, max. output: 0.35 mW, peak emission wavelength: 650 nm 0.026 mil)	
	FDA standards conforming type	Red semiconductor laser Class 2 (FDA) (modulated, max. output: 0.2 mW, peak) (emission wavelength: 650 nm 0.026 mil) (IEC / JIS: Class 1)	—	Red semiconductor laser Class 2 (FDA) (modulated, max. output: 0.35 mW, peak emission wavelength: 650 nm 0.026 mil) (IEC / JIS: Class 1)	
Material		Enclosure: Polyetherimide, Case cover: Polycarbonate, Front cover: Glass			
Cable		0.09 mm <sup>2</sup> 3-core shielded cable with connector, 0.5 m 1.640 ft long			
Cable extension		Extension up to total 10 m 32.808 ft is possible, with the optional cable			
Weight		Emitter: 15 g approx., Receiver: 15 g approx.			Emitter: 30 g approx., Receiver: 20 g approx.
Accessories		<b>MS-HLT1-1</b> (Sensor head mounting bracket): One set of two brackets for both the emitter and the receiver <b>CN-HLT1-1</b> (Sensor head to controller connection cable): 1 cable Laser beam alignment sticker: 2 pcs. Label set (FDA standards conforming type only): 1 set			<b>MS-LA3-1</b> (Sensor head mounting bracket): One set of two brackets for both the emitter and the receiver <b>CN-HLT1-1</b> (Sensor head to controller connection cable): 1 cable Laser beam alignment sticker: 2 pcs. Label set (FDA standards conforming type only): 1 set

Notes: 1) In case of an average sampling rate of 64 times.

2) Value calculated with the linear output allowance factor ( $\pm 3\sigma$ ) when connected to the controller included in the calculation of the detection width.

3) This value was obtained by converting the range of linear output fluctuation ( $\pm 3\sigma$ ) into a sensing width, assuming that the smallest sensing object blocks the beam at the approximate center of the beam diameter of  $\phi$  1 mm  $\phi$  0.039 in.

### Calculation unit

Item	Model No.	HL-AC1-CL
Connected controller	HL-AC1, HL-AC1P	
Current consumption	12 mA or less (supplied from the controller)	
Connection method	Connector	
Connection indicator	Orange LED (lights up when connected to the controller)	
Environmental resistance	Ambient temperature	0 to + 50 °C + 32 to + 122 °F (No dew condensation), Storage: - 15 to + 60 °C + 5 to + 140 °F
	Ambient humidity	35 to 85 % RH, Storage: 35 to 85 % RH
	Voltage withstandability	1,000 V AC for one min. between all supply terminals connected together and enclosure
	Insulation resistance	100 M $\Omega$ , or more, with 500 V DC megger between all supply terminals connected together and enclosure
	Vibration resistance	10 to 150 Hz frequency, 0.7 mm 0.028 in amplitude in X, Y and Z directions for 80 minutes
	Shock resistance	300 m/s <sup>2</sup> acceleration (30 G approx.) in X, Y and Z directions for three times each
Material	Enclosure: ABS, Indicator part: Acrylic	
Weight	50 g approx.	

## SPECIFICATIONS

### Controllers

Item	Type	NPN output	PNP output		
	Model No.	HL-AC1	HL-AC1P		
Applicable sensor head	HL-T1001A/T1001F, HL-T1005A/T1005F, HL-T1010A/T1010F				
Supply voltage / Current	12 to 24 V DC $\pm 10\%$ Ripple P-P 10% or less / 190 mA or less (when connected to the sensor head)				
Measuring cycle	150 $\mu$ s				
Linear output	Current / voltage output switchable (Note 1) <ul style="list-style-type: none"> <li>• During current output: 4 to 20 mA/F.S., Maximum load resistance: 300 <math>\Omega</math></li> <li>• During voltage output: <math>\pm 4</math> V/F.S., Output impedance 100 <math>\Omega</math></li> </ul> (In the monitor focus function, it can also be set at $\pm 5$ V, 0 to 5 V, etc.)				
	Temperature characteristics	$\pm 0.2\%$ F.S./ $^{\circ}$ C (Note 2)			
Settable average sampling rate (Note 3)	1 / 2 / 4 / 8 / 16 / 32 / 64 / 128 / 256 / 512 / 1,024 / 2,048 / 4,096				
Judgment output (HIGH, PASS, LOW)	NPN open-collector transistor <ul style="list-style-type: none"> <li>• Maximum sink current: 50 mA</li> <li>• Applied voltage: 30 V DC or less (between judgment output and 0 V)</li> <li>• Residual voltage: 1.2 V or less (at 50 mA sink current)</li> </ul>		PNP open-collector transistor <ul style="list-style-type: none"> <li>• Maximum source current: 50 mA</li> <li>• Applied voltage: 30 V DC or less (between judgment output and + V)</li> <li>• Residual voltage: 2 V or less (at 50 mA source current)</li> </ul>		
	Utilization category	DC-12 or DC-13			
	Number of outputs	HIGH / PASS / LOW 3 values output			
	Output operation	HIGH: ON when measured value > HIGH threshold value PASS: ON when HIGH threshold value $\geq$ measured value $\geq$ LOW threshold value LOW: ON when LOW threshold value > measured value			
Short circuit protection	Incorporated				
Laser OFF input	0 V connection: Laser emission halt Open: Laser emission • Applied voltage: 30 V DC or less (leak current: 0.1 mA or less)	+ V connection: Laser emission halt Open: Laser emission • Applied voltage: 30 V DC or less (leak current: 0.1 mA or less)			
Zero reset input	0 V connection: Zero reset operates Open: Zero reset ineffective • Applied voltage: 30 V DC or less (leak current: 0.1 mA or less)	+ V connection: Zero reset operates Open: Zero reset ineffective • Applied voltage: 30 V DC or less (leak current: 0.1 mA or less)			
Timing input	0 V connection: Effective Open: Ineffective • Applied voltage: 30 V DC or less (leak current: 0.1 mA or less)	+ V connection: Effective Open: Ineffective • Applied voltage: 30 V DC or less (leak current: 0.1 mA or less)			
Reset input	0 V connection: Effective Open: Ineffective • Applied voltage: 30 V DC or less (leak current: 0.1 mA or less)	+ V connection: Effective Open: Ineffective • Applied voltage: 30 V DC or less (leak current: 0.1 mA or less)			
Indicators	Laser emitting (LD ON)	Green LED (lights up during laser emission)			
	Judgment output	HIGH: Orange LED (lights up when measured value > HIGH threshold value) PASS: Green LED (lights up when HIGH threshold value $\geq$ measured value $\geq$ LOW threshold value) LOW: Yellow LED (lights up when LOW threshold value > measured value)			
	Enable (ENABLE)	Green LED (lights up during normal operation)			
	Zero reset (ZERO)	Green LED (lights up when the zero reset function is enabled)			
Main digital display	5 digit red LED display [RUN mode: Either the measured value (mm) or the hold value will be displayed.] [Reverse mode: The display orientation will be reversed.]				
Sub-digital display	5 digit yellow LED display [RUN mode: Either the resolution or laser beam reception amount will be displayed.] [THR mode: The threshold value will be displayed., Reverse mode: The display orientation will be reversed.]				
Main functions	<ul style="list-style-type: none"> <li>• Measured value display</li> <li>• Setting value, light amount value resolution display</li> <li>• Standard received light setting</li> <li>• Automatic scaling</li> <li>• Scaling</li> </ul>	<ul style="list-style-type: none"> <li>• Display reverse</li> <li>• ECO display</li> <li>• Display digits limitation</li> <li>• Sample hold</li> <li>• Peak hold</li> <li>• Bottom hold</li> <li>• Peak to peak hold</li> <li>• Self peak hold</li> <li>• Self bottom hold</li> </ul>	<ul style="list-style-type: none"> <li>• Zero reset</li> <li>• Initial reset</li> <li>• ON-delay timer</li> <li>• OFF-delay timer</li> <li>• ONE SHOT timer</li> <li>• Differentiation</li> <li>• Sensitivity selection</li> <li>• Threshold value direct setting</li> </ul>	<ul style="list-style-type: none"> <li>• Positioning teaching</li> <li>• 2-level teaching</li> <li>• Automatic teaching</li> <li>• Hysteresis width variability</li> <li>• Monitor focus</li> <li>• Non-measuring time setting</li> <li>• (A - B) calculation (Note 4)</li> </ul>	<ul style="list-style-type: none"> <li>• (A + B) calculation (Note 4)</li> <li>• Mutual interference prevention (Note 4)</li> <li>• Laser deterioration detection</li> <li>• Key lock</li> <li>• Zero reset memory</li> </ul>
Environmental resistance	Pollution degree	3 (industrial environment)			
	Ambient temperature	0 to + 50 $^{\circ}$ C + 32 to + 122 $^{\circ}$ F (No dew condensation), Storage: - 25 to + 65 $^{\circ}$ C - 13 to + 149 $^{\circ}$ F			
	Ambient humidity	35 to 85 % RH, Storage: 35 to 85 % RH			
	EMC	EN 50081-2, EN 61000-6-2			
	Voltage withstandability	1,000 V AC for one min. between all supply terminals connected together and enclosure			
	Insulation resistance	20 M $\Omega$ , or more, with 500 V DC megger between all supply terminals connected together and enclosure			
	Vibration resistance	10 to 150 Hz frequency, 0.7 mm 0.028 in amplitude in X, Y and Z directions for 80 minutes			
Shock resistance	300 m/s <sup>2</sup> acceleration (30 G approx.) in X, Y and Z directions for three times each				
Material	Enclosure: Polybutylene terephthalate, Transparent cover: Polycarbonate				
I/O cable	0.09 mm <sup>2</sup> 10-core composite cable, 2 m 6.562 ft long				
I/O cable extension	Extension up to total 10 m 32.808 ft is possible, with 0.09 mm <sup>2</sup> or more, cable. (Note 5)				
Weight	140 g approx.				

- Notes: 1) Switching between current and voltage is accomplished by a switch on the bottom of the controller.  
2) These are the temperature characteristics of the linear output when the sensor head is connected.  
3) The judgment output and linear output and linear output response time is calculated by (Measuring cycle)  $\times$  (Set average sampling rate + 1).  
4) The calculation unit is necessary.  
5) If the extension cable is longer than 10 m 32.808 ft, then it will not qualify for CE marking.

# HL-T1

## I/O CIRCUIT DIAGRAMS

### HL-AC1 NPN output type

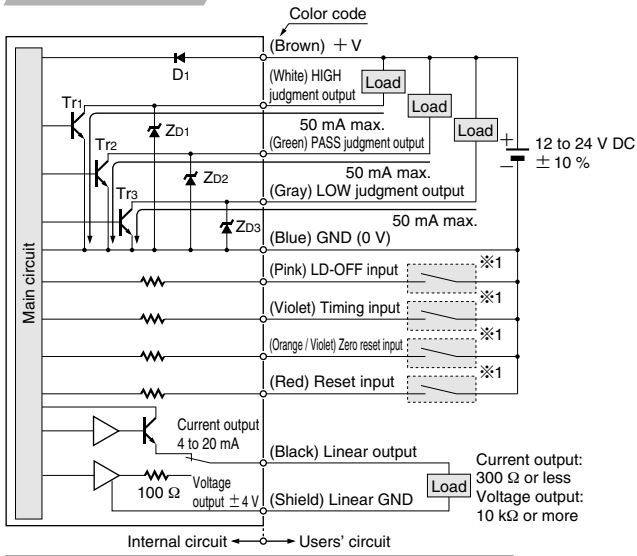

Symbols ... D: Reverse supply polarity protection diode  
ZD1, ZD2, ZD3: Surge absorption zener diode  
Tr1, Tr2, Tr3: NPN output transistor

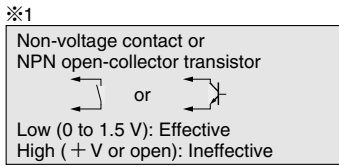

### HL-AC1P PNP output type

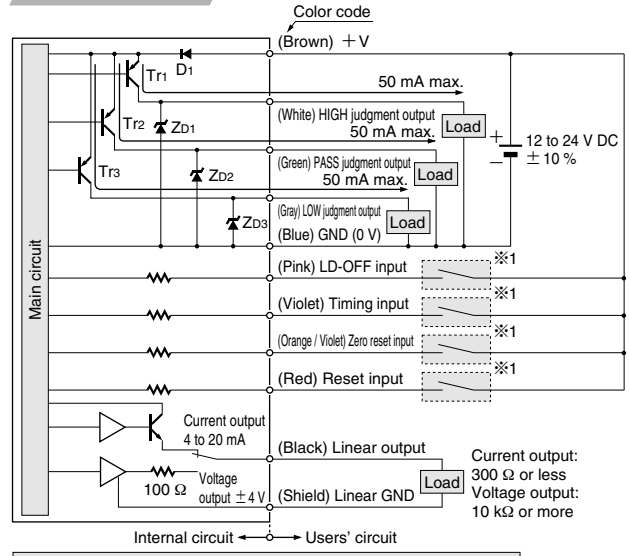

Symbols ... D: Reverse supply polarity protection diode  
ZD1, ZD2, ZD3: Surge absorption zener diode  
Tr1, Tr2, Tr3: PNP output transistor

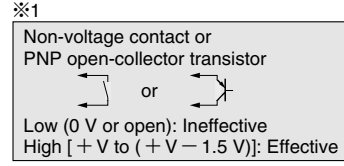

## SENSING CHARACTERISTICS (TYPICAL)

### HL-T1001A HL-T1001F

#### Correlation between transverse deviation and output voltage

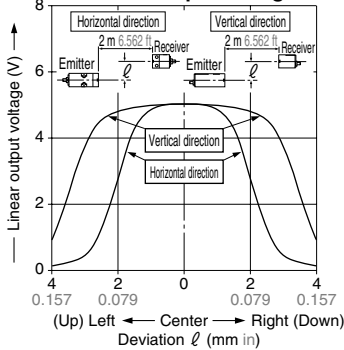

The left graph depicts the correlation between transverse deviation and output voltage when the full-scale setting ranges from 0 V (light beam is interrupted) to 5 V (light beam is fully incident), using the monitor focus function.

### HL-T1005A HL-T1005F

#### Correlation between transverse deviation and output voltage

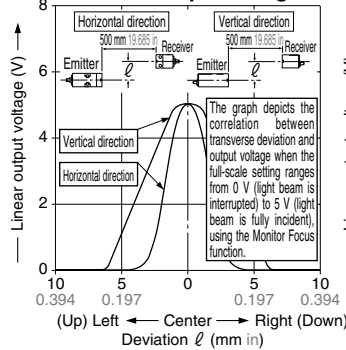

#### Correlation between interrupted beam width and output voltage

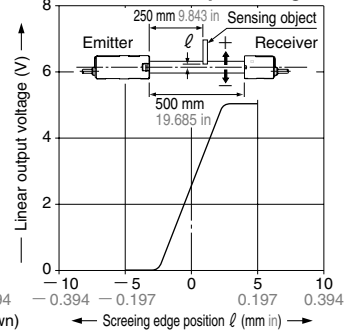

### HL-T1010A HL-T1010F

#### Correlation between transverse deviation and output voltage

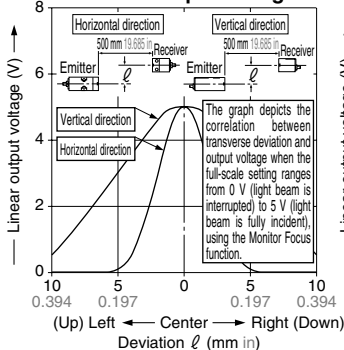

#### Correlation between interrupted beam width and output voltage

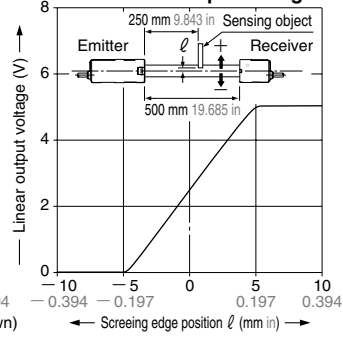

## PRECAUTIONS FOR PROPER USE



This product is not a safety sensor. Its use is not intended or designed to protect life and prevent body injury or property damage from dangerous parts of machinery. It is a normal object detection sensor.



This product is equivalent to a IEC / JIS Standard Class 1 Laser device. Do not expose your eyes to the laser beam through optical instruments, like a lens.

- For more detailed product information, please refer to the instruction manual accompanying this product.

### Safety measures for laser beam products

- The safety standard IEC Publication 60825 specifies the use of laser beam products. Please read it carefully before using the laser beam sensor.

### Functions

Function	Details
Zero reset function	The following tasks can be done by executing zero reset. <ul style="list-style-type: none"> <li>• The display value can be set at '0'.</li> <li>• The linear output when the display reads '0' is made the center output value of the 2 points set by monitor focus. (In the default state, the current output is 12 mA and the voltage output is 0 V.)</li> </ul>
Auto scaling function	The auto scaling function selects whether to display the laser beam reception amount in the main-digital display in 'mm' units or in '%' units, and determines whether the amount of laser beam received or the amount of laser beam interrupted is displayed. With the set standard laser beam reception amount as the reference value, the current laser beam reception amount (laser beam interrupted amount) is scaled automatically and is displayed as well as being output.
Standard received light setting	This function registers and stores the current laser beam reception amount in memory as the standard laser beam reception amount. The laser beam reception amount during full laser beam entry becomes the 100 % laser beam reception amount's full scale (F.S.). If this function is used, the display and the linear output are set on the full scale (F.S.) automatically. It can also be used to correct the laser beam reception amount when there is a change in the laser beam reception amount due to dirt, etc. on the front glass.
Scaling function	The scaling function is a function that changes the display value to the desired amount with respect to the setting value. At the desired distance, the display value can be input and changed.
Hysteresis width setting	This function sets the hysteresis to the desired value.
Monitor focus function	With this function, the linear output range and inclination, etc. with respect to the display value can be specified. Setting is done by determining the 2 output values with respect to the desired display values.
Differential function	This function makes the amount of change in the measured value an output value. Use this function when measuring if you are paying attention to changes in measured values, as when counting the number of workpieces, etc.
Display reverse function	The digital display's direction can be selected. The forward direction or the reverse direction to match the direction of installation on the equipment can be selected.
ECO display function	This function makes the display dark and saves electric power.
Display digits limitation function	This determines the number of display digits in the main-digital and sub-digital displays. If the number of digits is limited, the digits are turned off beginning with the lowest order digit.
Zero reset memory function	This selects whether or not to save the zero reset level in memory when the power is turned OFF. If you desire to reproduce the zero reset level from the previous operating session when you turn the power ON again, then enable this function. If this function is enabled, the zero reset level data are written into the EEPROM each time.
Key lock function	The controller's key input can be disabled. Once the key input is disabled, the controller will not accept any key inputs until the key lock is released. Use this function to avoid changing the setting by mistake.

### Connection

- This product is made to satisfy the specifications when the sensor head is combined with the controller. In any other combination, not only may it not satisfy the specifications, but could be the cause of breakdown. So by all means, use it so that there is a combination of the sensor head and controller.

### Functional description

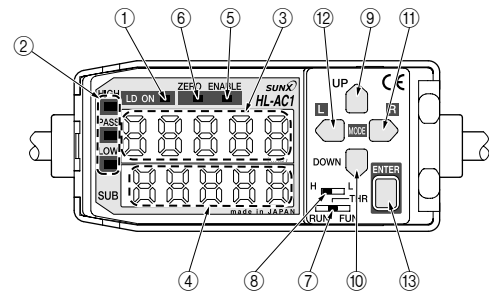

	Description	Function
①	Laser emitting indicator (LD ON) (Green LED)	Lights up when the sensor head is emitting laser beam.
②	Judgment output indicators (HIGH / PASS / LOW) (Orange / Green / Yellow LED)	HIGH: Orange LED (lights up when measured value > HIGH threshold value) PASS: Green LED (lights up when HIGH threshold value ≥ measured value ≥ LOW threshold value) LOW: Yellow LED (lights up when LOW threshold value > measured value)
③	Main-digital display (5 digit red LED)	When in the RUN mode, it displays the measured value (mm / %). During measurement hold, it displays the hold value (mm / %). In Reverse mode, the top and bottom are displayed in reverse.
④	Sub-digital display (5 digit yellow LED)	When in the RUN mode, it displays the threshold value, voltage / current value, light reception amount or resolution. When in the THR mode, it displays the respective threshold values. In reverse mode, the top and bottom are displayed in reverse.
⑤	Enable indicator (ENABLE) (Green LED)	Lights up when operation is normal. Goes off when operation is error (if the sensor head is not connected when the power is turned on).
⑥	Zero reset indicator (ZERO) (Green LED)	Lights up when the zero reset function is enabled.
⑦	Mode select switch	The following 3 modes can be selected. <ul style="list-style-type: none"> <li>• RUN mode: Measuring mode</li> <li>• THR mode: The threshold values are set in this mode.</li> <li>• FUN mode: Each of the settings are set in this mode.</li> </ul>
⑧	Threshold value select switch	When in the THR / RUN mode, this switches the set threshold value (HIGH / LOW).
⑨	Up key	<ul style="list-style-type: none"> <li>• RUN mode: Timing input</li> <li>• THR mode: Changes the threshold value (forward direction)</li> <li>• FUN mode: Changes the function setting value (forward direction)</li> </ul>
⑩	DOWN key	<ul style="list-style-type: none"> <li>• RUN mode: Press for 3 sec. or more: Standard light reception amount setting input</li> <li>• THR mode: Changes the threshold value (reverse direction)</li> <li>• FUN mode: Changes the function setting value (reverse direction)</li> </ul>
⑪	RIGHT key	<ul style="list-style-type: none"> <li>• RUN mode: Changes the contents of the sub-digital display (forward direction)</li> <li>• THR mode: Changes the threshold value digit (forward direction)</li> <li>• FUN mode: Sets function selection (forward direction)</li> </ul>
⑫	LEFT key	<ul style="list-style-type: none"> <li>• RUN mode: Changes the contents of the sub-digital display (reverse direction)</li> <li>• THR mode: Changes the threshold value digit (reverse direction)</li> <li>• FUN mode: Sets function selection (reverse direction)</li> </ul>
⑬	ENT key	<ul style="list-style-type: none"> <li>• RUN mode: Pressing for 1 sec. or more, executes zero reset. Pressing together with the RIGHT key for 3 sec. or more, cancels zero reset.</li> <li>• THR mode: When threshold value is blinking, the threshold value is set. When the threshold value lights up, teaching is executed.</li> <li>• FUN mode: When the set value is blinking, the value is set. When the setting is being initialized, pressing for a long time executes initialization.</li> </ul>

### Others

- This product outputs the judgment of the laser light analog quantity. Since there is variation in the light intensity between the center and the edges of the detection area, and the emitter side and the receiver side, the 'display value' does not equal 'the actual dimensions', so caution is necessary. Use the displayed dimensional value as a criterion.
- If the object being measured has a mirror surface or is a transparent body, it may be impossible to measure it accurately, so please exercise caution.
- Absolutely do not attempt to disassemble this product.

# HL-T1

## DIMENSIONS (Unit: mm in)

### HL-T1001A(F) HL-T1005A(F) Sensor head

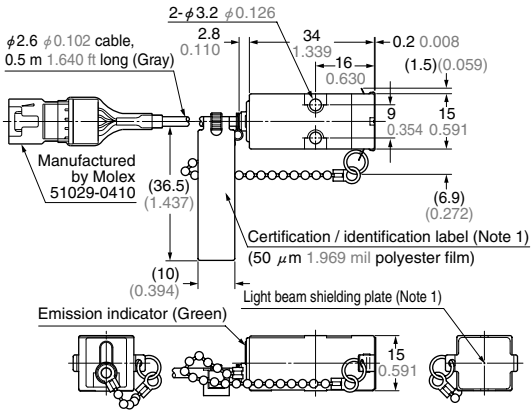

**Emitter**

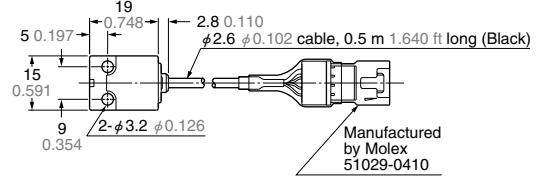

**Receiver**

Notes: 1) IEC / JIS conforming products do not contain light beam shielding plate, or certification / identification label.  
2) The receiver of HL-T1001A(F) does not incorporate a slit.

### HL-T1010A HL-T1010F Sensor head

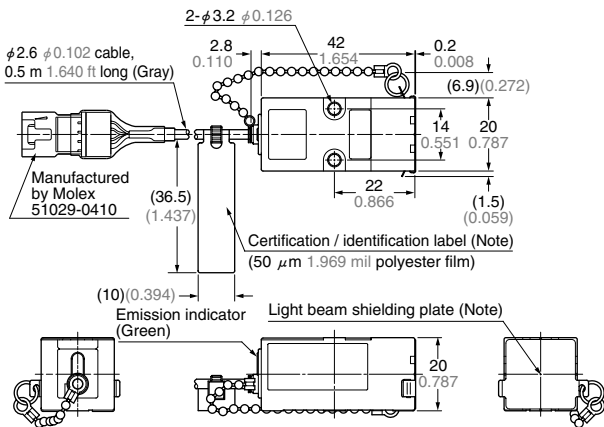

**Emitter**

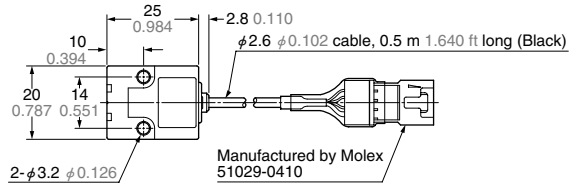

**Receiver**

Note: IEC / JIS conforming products do not contain light beam shielding plate, or certification / identification label.

### HL-AC1 HL-AC1P Controller

#### Mounting drawing with a mounting bracket MS-HLAC1-1 (Optional)

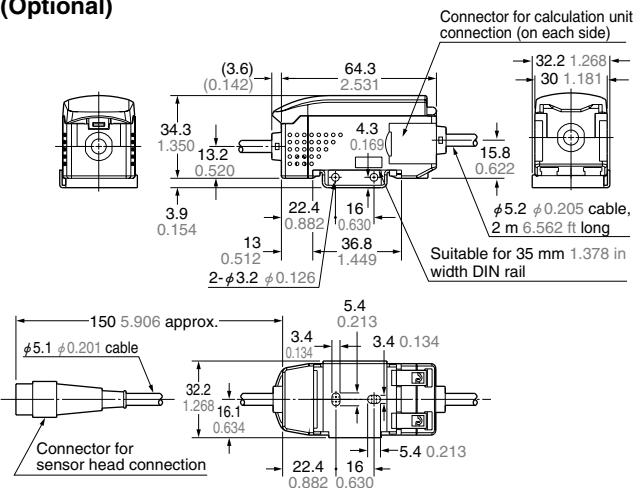

### HL-AC1-CL Calculation unit (Optional)

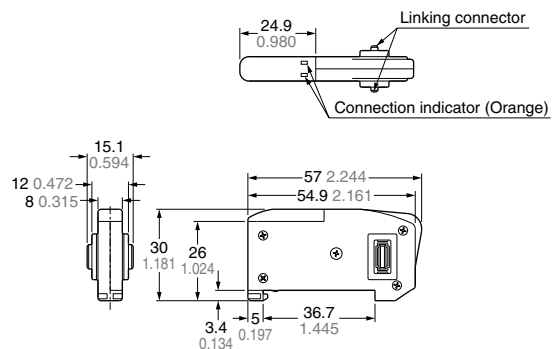

## DIMENSIONS (Unit: mm in)

### MS-HLT1-1

Sensor head mounting bracket for HL-T1001A(F) / HL-T1005A(F)

[This accessory is included with the HL-T1001A(F) / HL-T1005A(F). Also available for purchase separately.]

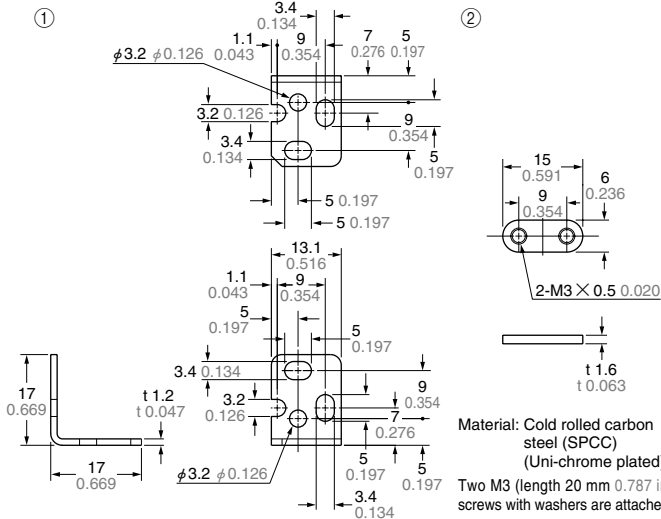

### Assembly dimensions

Mounting drawing with HL-T1005A's receiver

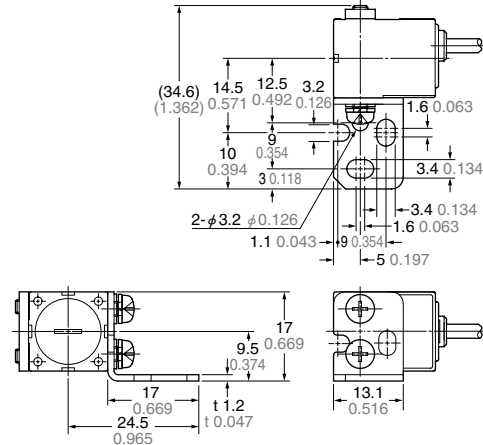

### MS-LA3-1

Sensor head mounting bracket for HL-T1010A(F)

[This accessory is included with the HL-T1010A(F). Also available for purchase separately.]

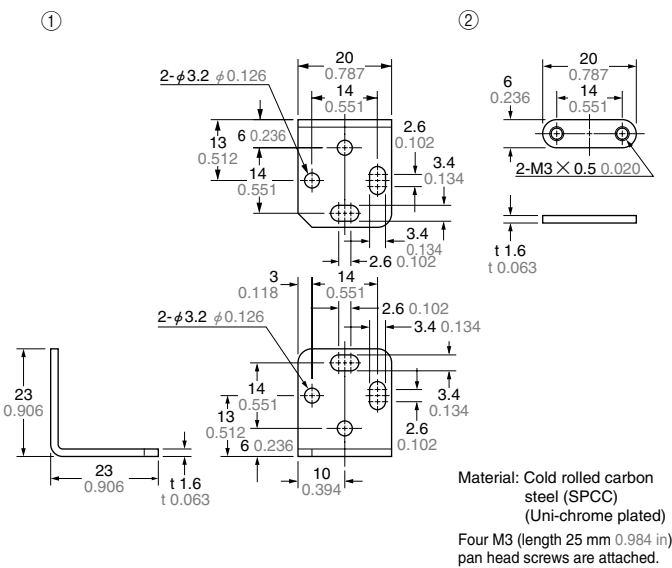

### Assembly dimensions

Mounting drawing with HL-T1010A's receiver

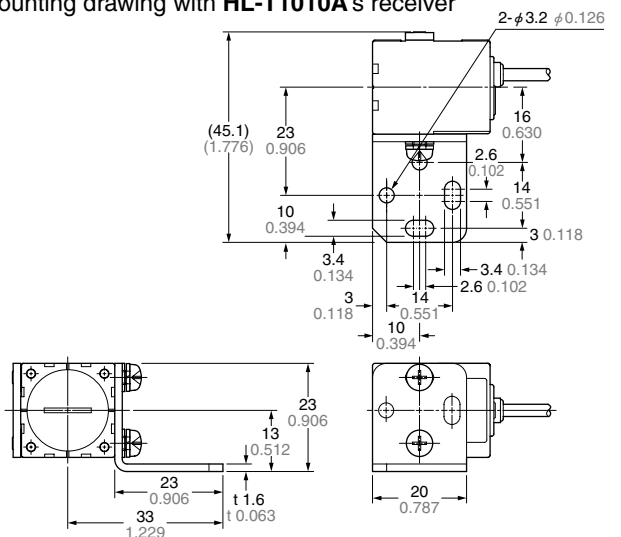

### MS-HLAC1-1

Controller mounting bracket (Optional)

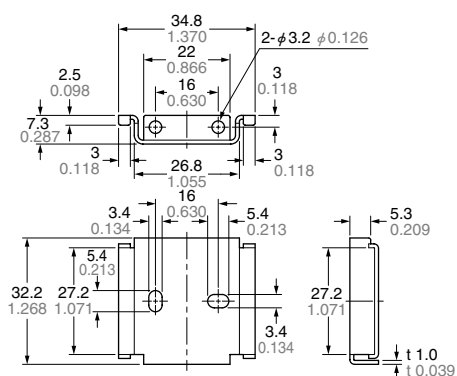

### CN-HLT1-1

Sensor head to controller connection cable

(This accessory is included with the sensor head. Also available for purchase separately.)

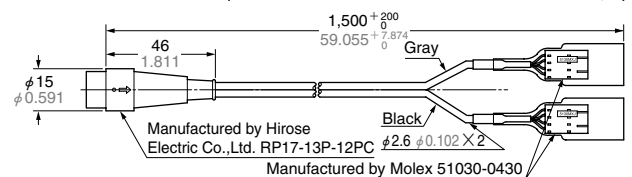

# HL-T1

## DIMENSIONS (Unit: mm in)

### HL-T1SV1

Side-view attachment for HL-T1001A(F) / HL-T1005A(F) (Optional)

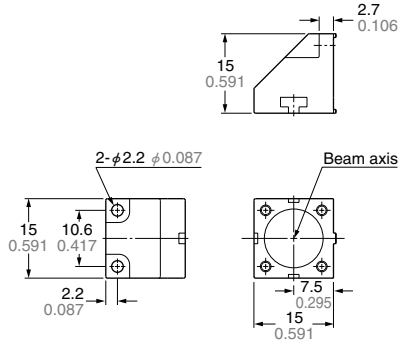

### Assembly dimensions

Mounting drawing with HL-T1005A's receiver

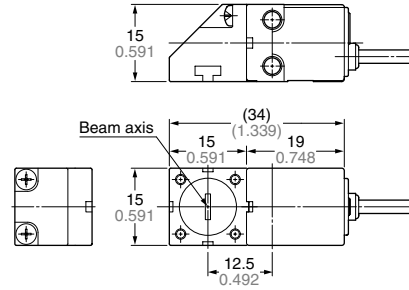

Material: Polyetherimide (Enclosure), Glass (Front cover)  
Two M2 (length 6 mm 0.236 in) screws with washers are attached.

### HL-T1SV2

Side-view attachment for HL-T1010A(F) (Optional)

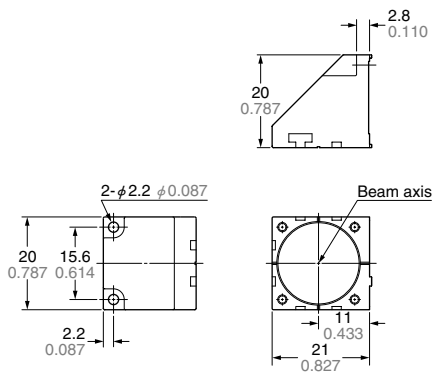

### Assembly dimensions

Mounting drawing with HL-T1010A's receiver

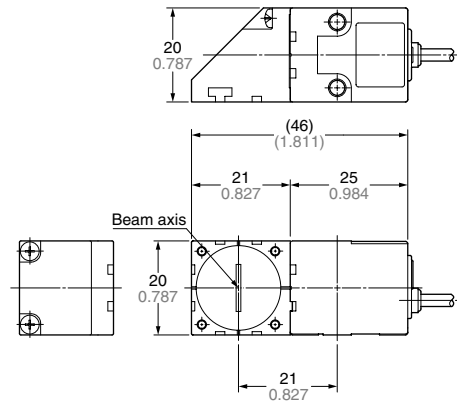

Material: Polyetherimide (Enclosure), Glass (Front cover)  
Two M2 (length 6 mm 0.236 in) screws with washers are attached.